

CORRAIL 2000

SPEED SENSING AND ODOMETRY

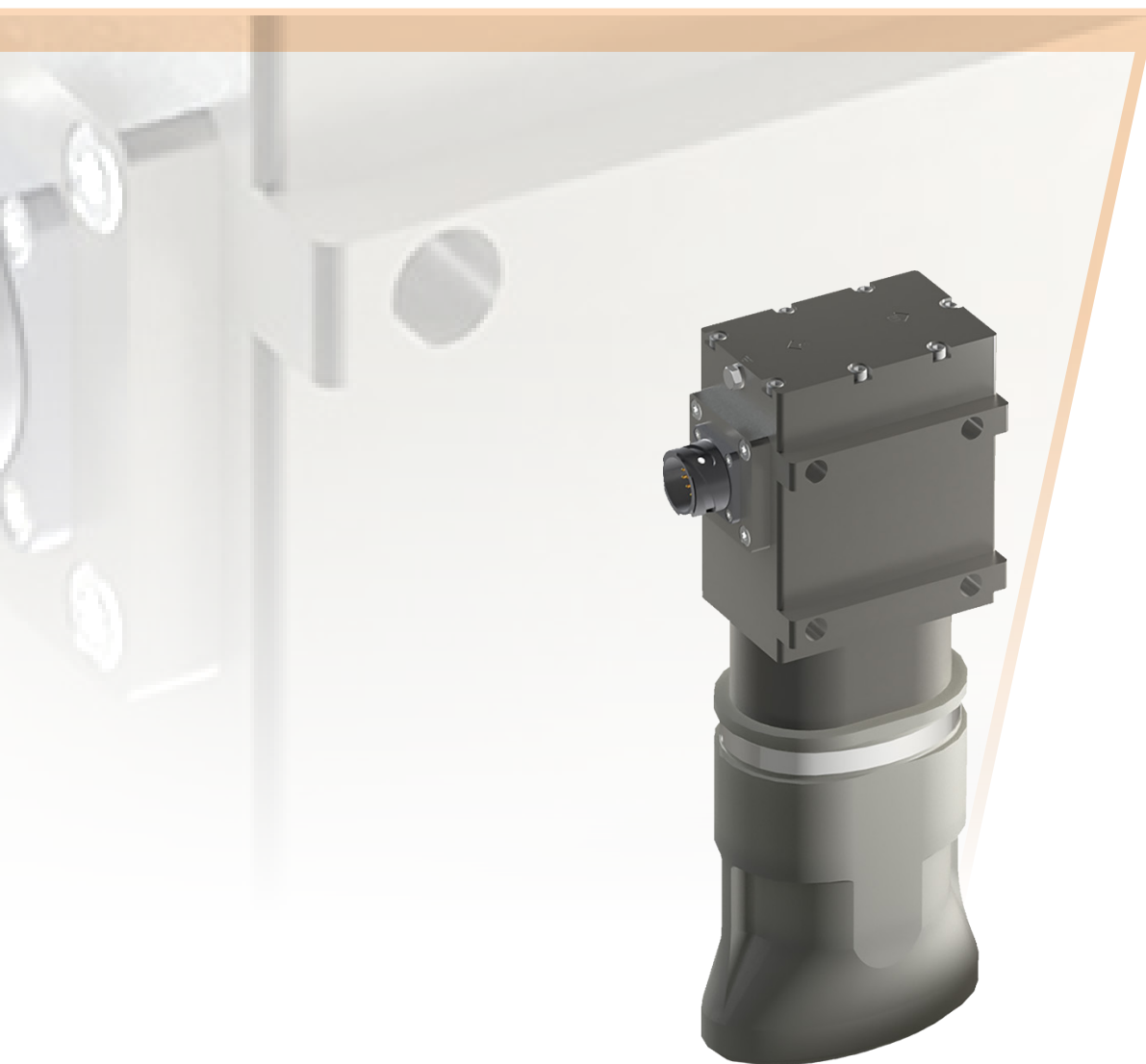

SPEED SENSING AND ODOMETRY

TRUE SPEED OVER GROUND SENSORS (TSOG)

ON-BOARD ELECTRONICS

Rail vehicles are equipped with speed, direction and distance detection systems to ensure safe and visible operation on today's busy, centrally supervised networks. HaslerRail offers a comprehensive range of products to satisfy the most demanding detection requirements and applications. In addition to traditional pulse generators and hall effect sensors we also include non-contact speed and distance sensors, so-called True Speed Over Ground Sensors:

The optical CORRail sensor offers contactless, track-bed independent, direct measurement of a rail vehicle's speed and operating direction, using the railhead as a reference.

The DOPRail radar sensor measures the vehicle speed over ground using the Doppler effect.

GENERAL INFORMATION

CORRail 2000 is the latest iteration of HaslerRail's bogie-mounted speed sensor, now accommodating speed detection and signal conditioning in one housing and obviating the need for an auxiliary filter box. The speed reference target for the device's infrared LEDs is the rail head rather than the track bed. The uniform presentation of the rail head to the LEDs provides a consistent target for accurate optical correlation of speed and direction.

The splash guard is fabricated from a tough elastomer type polymer. Its patented design provides protection for the device's external lens by discouraging the ingress of residual rain water and other debris from the rail head. A heated version of the splash guard is also available for ice-free operation of CORRail 2000.

CORRail 2000

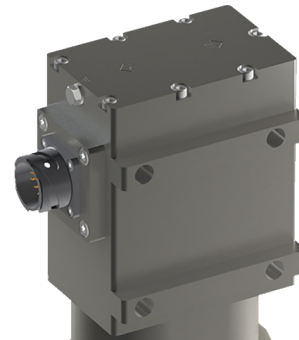

CORRail 2000's mounting bracket, connector, cable and splash guard are compatible with those of the CORRail 1000.

MAIN BENEFITS

- ✓ Speed sensing is unaffected by wheel slip / slide
- ✓ Availability > 99.5%
- ✓ Splash guard protection extends cleaning interval to greater than six months
- ✓ No calibration is required as sensing is independent of wheel diameter
- ✓ Precise speed and distance readings are suitable of use with ETCS and ATO

MAIN CHARACTERISTICS

Technical Data	Value
Speed Measurement	0.2...600 km/h Forward-/ backward detection
Error of the Mean	1 km/h...100 km/h < 0.2 km/h 100 km/h...600 km/h < 0.2 %
Statistical Error	1 km/h...100 km/h < 0.1 km/h 1σ Limit 100 km/h...600 km/h < 0.1 % 1σ Limit
Latency	<25 ms
(Re-)Boot Time	<1 s
Interfaces	RS485
Power Supply	24 ... 110 VDC
Power Consumption	20 W
Useful Life	20 years
MTBF	> 500.000 h
Weight	< 4000 g
Protection class	IP68 / IP69K

STANDARDS

Our products are fully compliant and type tested according to the following standards:

- **EN 50155:2017** | Railway applications - Electronic equipment used on Rolling Stock
- **EN 50657:2017 - Basic Integrity** | Railways Applications - Rolling stock applications Software on Board Rolling Stock
- **EN 50121-3-2:2016 +A1:2019** | Railway applications - Electromagnetic compatibility - Part 3-2: Rolling stock - Apparatus
- **EN 50126-1:2017 / EN 50126-2:2017** | Specification and demonstration of reliability, availability, maintainability and safety (RAMS)
- **EN 45545-2:2020 HL3** | Fire protection on railway vehicles - Part 2: Requirements for fire behavior of materials and components
- **2011/65/EU (ROHS)** | Restriction of the use of certain hazardous substances (RoHS) in electrical and electronic devices 2011
- **1907/2006EU (REACH)** | Railway applications - Electronic equipment used on Rolling Stock
- **EN 50155:2017** | Registration , Evaluation , Authorization and Restriction of Chemicals 2006

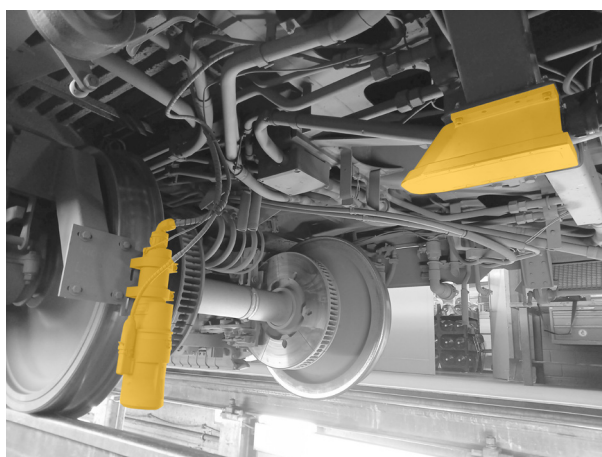

Installation Example

PRODUCT HIGHLIGHTS

COMPARISON

// **CORRail vs. Doppler radar technologies**

- Unaffected by changes in rail bed substrate
- Sensing is affected much less by snow and ice
- Suitable for use on monorail transport systems (utilises concrete beam as speed reference target)
- Higher resolution sensing of speed and distance
- Bogie-mounted therefore independent of vehicle body attitude on tilting trains
- Although markedly different in sensing methods and error characteristics, CORRail and Doppler technologies are complementary if combined in an odometry system

// **CORRail vs. optical pulse generator**

- Speed sensing is unaffected by wheel slip / slide
- No calibration is required as sensing is independent of wheel diameter
- No adjustment required to accommodate wheel wear or change of wheelset
- Higher resolution sensing of speed and distance
- Is suited for traction control systems

Odometry Solutions

Our comprehensive portfolio of odometry solutions encompasses service-proven optical pulse generators and Hall Effect sensors to the latest developments in non-contacting speed sensing (CORRail and DOPRail) for measuring the true speed-over-ground (TSOG) of rail vehicles.

HaslerRail's odometry products are available in several variants to meet the most exacting needs of system integrators and rail operators. The complete sensor portfolio can be networked with our TELOC series of on-train monitoring recording systems (OTMR). The data from multiple sensors is processed and evaluated to ascertain the precise speed and position of the vehicle.

Our customers can specify the sensor type, configuration and data evaluation level to align with their requirements in terms of performance, maintenance schedules and cost.

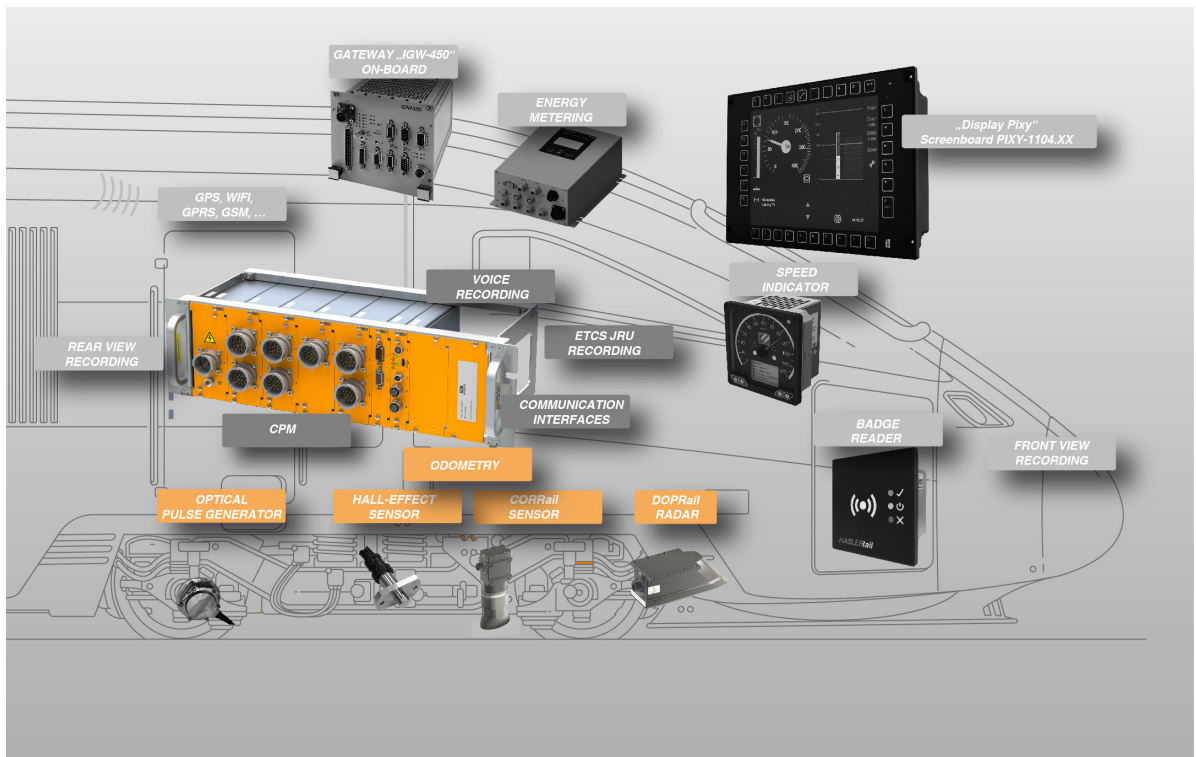

HASLERRail
PIXY

Sécheron Hasler GROUP

Copyright© • 2022 • HaslerRail AG

This document is not contractual and contains information corresponding to the level of technology at the date of printing. HaslerRail reserves the right to modify and/or improve the product, whose characteristics are described in these documents, as required by new technology at any time. It is the purchaser's responsibility to inform himself, no matter what the circumstances, of the product's maintenance conditions and requirements. HaslerRail reserves all rights, especially those arising from our "General Delivery Conditions".

📍 **HaslerRail AG**

Freiburgstrasse 251
3018 Bern
CH-Switzerland

Tel: +41 31 990 71 11
Fax: +41 31 990 72 22
info@haslerrail.com

www.haslerrail.com